

# SMS-7100

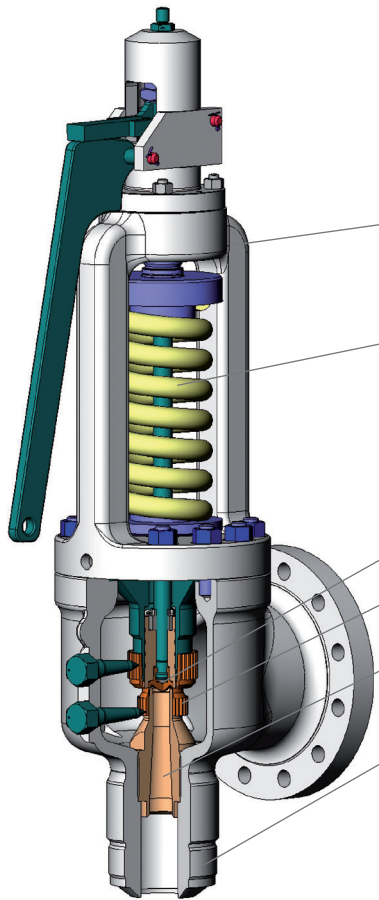

Weatherhood is available to protect the spring and the upper structure

Precision alloy wound spring for precise and repeatable performance

Flexible lip seat for superior tightness

Double ring design, 3% overpressure and 4% blowdown

High capacity discharge

Flanged or welded connection available

## Main features

Flanged, spring loaded, direct acting, full nozzle safety relief valves for steam service (ASME Sect.I).

Media: steam (suitable also for gas).

Orifices: from "D" to "R2".

Set pressure range: up to 206 bar.

Temperature range: up to 566 °C.

Overpressure: 3% or 0.14 bar.

Blowdown: 4% or 0.28 bar.

Materials: carbon steel, alloy steel and other materials upon request.

Options: lifting lever, test gag, finned bonnet, hardened seat.

## Sizes / Pressure Classes

Size inlet & outlet: from NPS 1 to NPS 8 & from NPS 1 1/2 to NPS 12.

Rating: up to ASME 2500.

## Design Codes & Product Standards

EN ISO 4126-1, EN 12516, EN 12952-10, EN 1092, ASME B16.34, ASME B16.5, ASME Sect.I.